

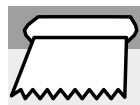

Ambient Temperature
Min. 15°C



Substrate Temperature
Min. 15°C

Important note: Before starting to install the wall covering, it is essential to examine it carefully to detect any visual problems. In the event of visual defects, please inform GERFLOR and do not begin installation without its agreement.

Product	Dimensions	Installation direction	Weld treatment
Mural Ultra Design	6'6"	Same	CR 40
Mural Calypso	6'6"	Reverse	CR 40

1. THE SUBSTRATE

- 1.1. Installation of this wall covering must be carried out on a substrate that complies with the GERFLOR Installation Guide. "Advice on preparing new and renovated wall surfaces".
- 1.2. Walls must be flat and vertical in accordance with local standards.
- 1.3. Reminder:
 - Local planarity: 1 mm under the 20 cm rules.
 - General planarity: 5 mm under the 2.00 m rules.
 - Verticality: 5 mm under the 2.50 m rules.
 - Average hardness: 45 shore C.
 - Moisture less than 5% by weight.

2. WALL PREPARATION

- 2.1. The substrates must be free of moisture, mildew and dirt (ink, grease pencils, graffiti, etc.).
- 2.2. A primer compatible with the substrate and adhesive is applied to homogenize porosity.
- 2.3. Preparation for covering the skirting board:
 - The difference in thickness is compensated for by a filler or reduction profile.

3. WALL COVERING INSTALLATION

Space widths 1 mm to 1.5 mm apart to facilitate bevelling with a triangular gouge.

3.1. For vertical installation

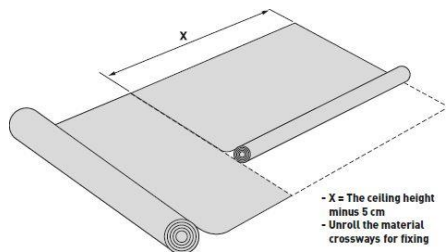

3.2. For horizontal installation

Horizontal installation requires the material to be cut to the required length and width.

3.3. MATERIAL PLACEMENT

- Minimum substrate temperature: 10°C.
- Minimum ambient temperature for installation: 10°C.
- Allow the wallcovering to reach the minimum installation temperature (15°C) for 24 hours.

3.4. PLUMB LINE

Vertical installation

- Draw a starting plumb line, the position of which will depend on the size of the part, to avoid welding close to or on a corner. The weld must be positioned more than 10 cm from the nearest corner.
- Draw a second vertical line at one web width to determine the area to be glued.

Horizontal installation

- Draw a plumb line at the desired height, depending on the type of finish, along the baseboard rise.

3.5. GLUING AND APPLYING THE STRIPS

Due to the heavy weight of the covering, the wall will be glued using a single-sided, water-based dispersion adhesive (acrylic) for PVC wall coverings.

Application is by simple gluing. Gluing is usually carried out with an A4 spatula (according to TKB specifications), then "rolled" with a medium-long nap roller. The glue must be evenly distributed.

As adhesives evolve regularly, it is essential to ensure that the adhesive used is compatible with the back of the covering and the substrate. The adhesive supplier's recommendations must be followed.

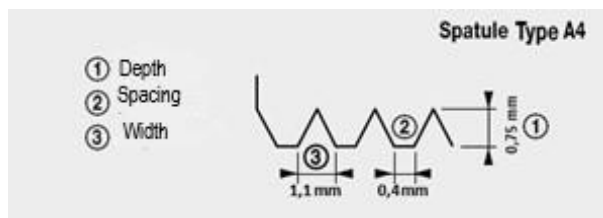

WARNING!

- Strictly follow the glue supplier's instructions and respect the gumming time.
- Observe the gumming carefully time according to temperature, ambient humidity, substrate porosity and adhesive consumption.
- Insufficient exfoliation time can lead to blistering.
- Exceeding the gumming time may result in poor glue transfer to the material.
- Avoid overlapping 2 adhesive films when re-gluing.

- Post the first sheet on the plumb line and the subsequent ones, leaving a 1 mm gap between each sheet.

3.6. CORNER INSTALLATION

For inside and outside rounded corners, it's essential to soften the material without deforming it, using a heat gun.

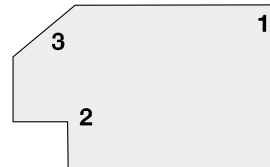

3.7. Recessed angle: 1

Glue a CA12 bead in the corner before installing the wall covering.

External angle: 2

The coating may whiten or crack during application. We recommend:

- Either cut it to size or fit a stainless-steel corner protector (see point 3.8.7).
- Either round off the corner with sandpaper or sanding stone before gluing the wallcovering.

Open angle > 90°: 3

For open angles > 90°. There are water-based neoprene glues and/or double-sided adhesives recommended by glue manufacturers such as BOSTIK, MAPEI, UZIN.

GERFLOR recommends that you refer to the technical data sheets of these glues or adhesives for their instructions for use.

3.8. SMOOTHING

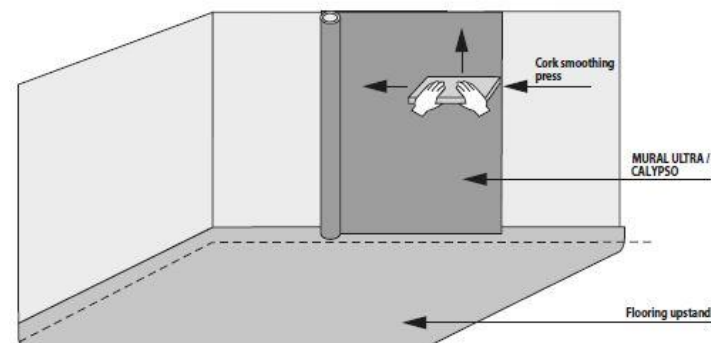

Chase the air from an edge halfway up the strip, using a cork smoothing press (pressure board).

Outgoing corner with finishing angle:

- Display the wall covering on the wall.
- Mould to the corner.
- Cut the covering.
- Display the coating on the second part of the corner.
- Mould to the corner.
- Cut the covering.
- Fasten the corner angle and its protective cover.

Rounded exit angle:

- Display the wall covering on the wall.
- Mould to the corner.
- Soften the material without deforming it, using a heat gun.
- Smooth out the corner passage and continue past the corner.

Recessed angle:

- Roll the material to the corner.
- Fold it over to match the shape of the cord.
- Soften the material without deforming it, using a heat gun.
- Display the material by passing an angle wheel over it.

3.9. CONNECTION TO FLOOR COVERING**Covering the skirting rise**

- 3.9.1 The wall covering overlaps the baseboard of the floor covering by at least 3 cm.
- 3.9.2 The wallcovering is glued to the baseboard using acrylic adhesive or double-sided tape (dry adhesive).
 - 3.9.2.1 Compensate for wall covering with wall filler or decrease profile (ref.: 0490)
 - 3.9.2.2 Protect the covering 3 cm below the overlap with an adhesive in the case of covering with acrylic glue.
 - 3.9.2.3 Apply double-sided adhesive tape to the wallcovering trim and 3 cm to the skirting, or apply the adhesive stopping at the protective adhesive; remove the protective adhesive before posting the wallcovering.
 - 3.9.2.4 The covering is applied by heating with a heat gun and trowelling with a flat trowel.

Welding to vinyl flashcoving

This solution is ONLY possible with MURAL ULTRA DESIGN and a homogeneous or heterogeneous wall covering with a maximum thickness of 2 mm. All traces of adhesive must be removed from the joint before welding. We recommend chamfering with a chamfering triangle. The weld must be perfectly fused to avoid breakage over time. Use the RAPID ULTRA nozzle. Scrupulously follow the recommendations given in the table below.

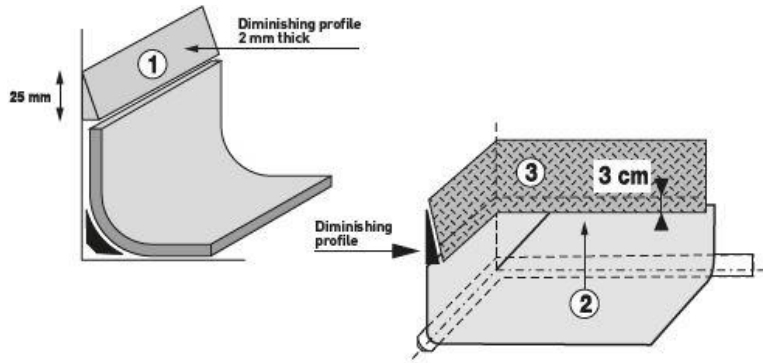

Joint treatment

FIXING LENGTHS	MURAL ULTRA OR MURAL CALYPSO: SPACING BETWEEN LENGTHS: 1 MM + 0.5 - 0MM		
	TOOLS	USE	COMMENTS
CHAMFERING	Ensure that joints are even. Eliminate traces of adhesive that stop the welding bead from fusing		
	Triangular scraper	Angle the triangular scraper so that each edge is chamfered separately and identically Chamfering may require several passes.	The recommended tools are available from Gerflor, Janser, Romus or Wolff
WELDING CR40 / MURAL ULTRA CR41 / MURAL CALYPSO	Hot Jet S or Leister Triac type fitted with an Ultra Fast nozzle Ref.: Gerflor 0563 0001	CR 40 or CR 41 welding rope: Air gun: Hot Jet S: position 4 (80 l of air / mn) - Leister Triac: 230 l of air / mn Temperature: 450 to 500°, position between 4 and 5	
MAKING FLUSH	Sum levelling spatula Mozart levelling spatula 1/4 moon cutter + levelling guide	A levelling spatula sharpened in the middle levels only the bead and avoids cutting the material	

3.10. FINISHING TOUCHES - CONNECTION WITH TECHNICAL COMPONENTS

The bonding, cutting, and finishing of the wall covering around the elements of the technical trades must be particularly careful and comply with our recommendations. Filling must be carried out by the technical trades concerned.

Wall covering / CEILING connection

Puttying - Ref.: SIMSON 007 by BOSTIK for a minimum of 8 mm on either side of the ceiling/wall angle.

Wall mounts

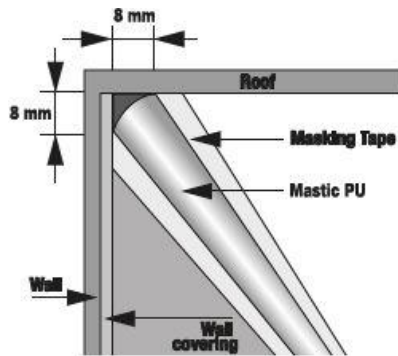

The washbasin, sink corner protectors on protruding corners access hatches

Polyurethane sealant

Wall bushings (heating, sanitary)

E.C./E.F. inlet: shower, washbasin - EU evacuation - Heating: Sealant

Frame (joinery)

Frames - Window-frames: Puttying.

Electricity

Switch - Socket outlet.

cf. NFC 15-100 standard (May 1991 addendum)

Minimum distance from an electrical point, starting from the fixed shower head or from the start of the flexible hose: 1.20 m.

Ventilation

Natural: low inlet / high outlets. VMC - wall outlets: puttying.

EXTERNAL angle protection

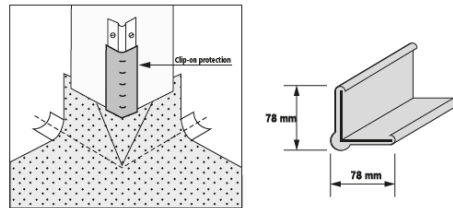

4. INSTALLATION USING GERFIX TPS+ ACRYLIC ADHESIVE

- 4.1. Always refer to the Gerfix TPS+ adhesive data sheet.
- 4.2. Recommended trowel size is 1/32" x 1/16" x 1/32", covering 170 to 220 square feet per US gallon.
- 4.3. To ensure uniform adhesion over the entire surface, apply a sufficient quantity of adhesive in one go.
- 4.4. Maintain an even spread rate. Replace trowel (or trowel blade) for each bucket used. Immediately after trowelling the adhesive onto the substrate, use a medium nap paint roller saturated with adhesive to smooth out visible trowel marks and even out the adhesive. The use of a double-armed roller is recommended to ensure an even layer of adhesive.
- 4.5. Immediately after trowelling the adhesive onto the substrate, use a medium nap paint roller saturated with adhesive to smooth out visible trowel marks and even out the adhesive. The use of a double-armed roller is recommended to ensure an even layer of adhesive.
- 4.6. Once the adhesive has been applied, fold or roll the liners 4 to 6 inches into the still-moist adhesive. This will make it easier to fold or roll the second half and avoid overlapping the glue line. If this method is not followed, the glue line mark may show through the covering.
- 4.7. The adhesive's "open time" depends on the porosity of the substrate, temperature and humidity. It is important that installers familiarize themselves with the adhesive before starting installations.



INSTALLATION INSTRUCTIONS

MURAL ULTRA DESIGN / MURAL CALYPSO

<i>Application features on porous substrates</i>		
	<i>Open time</i>	<i>Work time** (hours)</i>
Gerflor Wallcovering	20 to 40 minutes (to obtain a tacky*** state)	Up to 1.5 hours

* **Opening time:** this is the waiting time before the wallcovering can be laid.

** **Working time** is the window of time required for the adhesive to accept the wallcovering.

*** **Tacky:** when the adhesive starts to become translucent and there is a slight transfer to the fingers when lightly touched.

Note: for non-porous substrates such as metal or existing coverings, allow the adhesive to dry completely, without transferring to the fingers to the touch, then immediately install the floor covering and tamp it down with a pressure board and/or hand roller.

5. Gluing and installation

Due to the weight of the wallcovering, the wall will be glued with a high-grade acrylic adhesive.

The adhesive is applied evenly with a recommended finely serrated trowel, size 1/32" x 1/16" x 1/32", then "rolled" with a medium "nap" paint roller.

NOTE

- Follow the adhesive manufacturer's instructions regarding waiting time.
 - It is essential to use the adhesive and spatula recommended by Gerflor.
 - Room temperature and humidity, substrate absorption and adhesive consumption all play a crucial role in achieving perfect adhesion.
 - Too short a waiting time can lead to the formation of unwanted bubbles.
 - Waiting too long will result in inadequate transfer of adhesive to the wallcovering.
 - Avoid overlapping two glue films when re-gluing.
 - Apply the first panel, respecting the plumb line, then proceed in a similar way for subsequent panels.
- **HEAT WELDING - REFER TO THE DOCUMENT "HEAT WELDING OF GERFLOR VINYL PRODUCTS".**
 - **ONCE INSTALLATION IS COMPLETE**
 - Perform a visual inspection of the project.
 - Check each weld.
 - Repair any imperfections before leaving the site.
 - Ensure that all vertical obstructions such as door frames are properly trimmed and sealed with acrylic, silicone, or equivalent sealant.
 - To maximize the aesthetic appeal and ease of maintenance of your newly installed floor covering, provide your customer with a copy of **Gerflor's Maintenance Guide**.